



## **DATASHEET**

---

Electrical Power System (EPS I & EPS I Plus)

1	Change Log .....	3
2	Acronyms List.....	4
3	Highlighted Features .....	5
4	System Description .....	5
4.1	<b>EPS Module Monitoring</b> .....	6
4.2	<b>EPS Module Control</b> .....	6
5	Block Diagram.....	7
6	Connector Pinout.....	8
6.1	<b>Location of Connectors</b> .....	8
6.2	<b>H1 &amp; H2 - PC/104 Stack Connector</b> .....	9
6.3	<b>H1 - Stack Connector</b> .....	9
6.4	<b>H2 - Stack Connector</b> .....	10
6.5	<b>P1 to P6 - EPS Solar Panel Connectors</b> .....	10
6.6	<b>USB Connectors</b> .....	11
7	Electrical Characteristics.....	11
8	Mechanical Drawing .....	14
9	Environmental and Mechanical Test.....	17
10	Handling and Storage .....	17
11	Warnings.....	18

# ELECTRICAL POWER SYSTEM (EPS I & EPS I PLUS) DATASHEET

This datasheet details the applications, features and operation of EnduroSat's Electrical Power System (EPS I and EPS I Plus).

Please read this datasheet before unpacking and using the module to ensure safe and proper use.

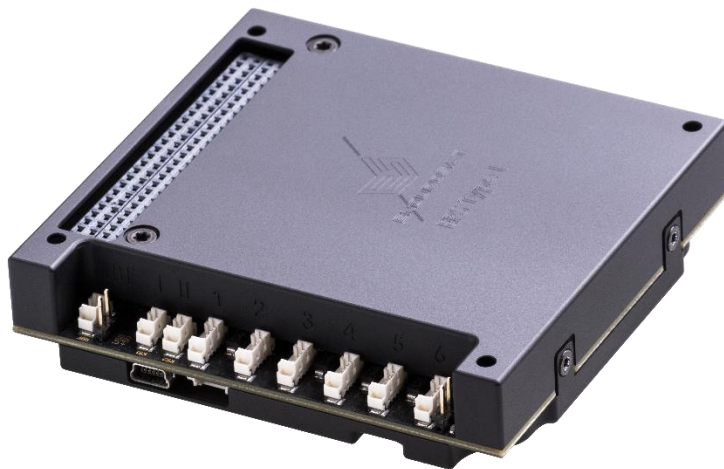

Figure 1: EnduroSat's Electrical Power System (EPS I and EPS I Plus)

## 1 CHANGE LOG

Date	Version	Note
1208/2018	Rev 1.0	Initial document

## 2 ACRONYMS LIST

BCR	Battery Charger Regulator
EMC	Electromagnetic Compatibility
EOC	End of Charge
EPS	Electrical Power System
ESD	Electrostatic Discharge
GPO	General Purpose Output
JMP	Jumper
I2C	Inter Integrated Circuit
Li-Po	Lithium Polymer Battery
LUP	Latch-up Protected
MPPT	Maximum Power Point Tracking
PCM	Protection Circuit Module
RBF	Remove Before Flight
RTC	Real Time Clock
UART	Universal Asynchronous Receiver/Transmitter
USB	Universal Serial Bus
LDO	Low Dropout Regulator
MCU	Microcontroller
VCP	Virtual COM Port

### 3 HIGHLIGHTED FEATURES

- Three Solar Panel Channels (one for each CubeSat axis: X, Y and Z)
- Input voltage (per Solar Panel Channel): up to 5.5 V
- Input current (per Solar Panel Channel): up to 1.8 A
- Six connectors for the solar panels
- Integrated blocking diode for each solar panel connector
- Battery pack power: 10.2 Wh (20.4 Wh for two battery packs)
- Battery pack voltage: 3.7V nominal
- Very low power consumption in normal operation: 20mA @3.7V battery
- Stackable battery packs: up to 8A
- Output power buses: 3.3V, 5V, BCR (5Vmax) and 'battery raw'
- 3.3V and 5V latch-up protected outputs
- Interfaces: UART, I2C, USB (Virtual COM Port)
- Two deployment and one Remove Before Flight (RBF) switches can be connected
- Six general purpose outputs for shutdown/reset of external modules
- USB debug & battery charger
- Weight: EPS I = 208g (includes 1 battery pack)
- Weight: EPS I Plus = 292g (includes 2 battery packs)

### 4 SYSTEM DESCRIPTION

EnduroSat's EPS I and EPS I Plus modules are ideal for 1U, 1.5U and 2U CubeSat satellites. The EPS I module has one integrated Li-Po battery pack while EPS I Plus has two Li-Po battery packs connected in parallel. The single battery pack consists of two Li-Po battery cells connected in parallel. Each battery cell within each battery pack has an integrated Protection Circuit Module (PCM) which prevents over-current, over-charge and over-discharge. Additionally, each battery pack has three independent heaters to prevent charging below 0 °C – a special algorithm optimizes the heater power consumption in relation to the temperature. Firmware algorithm is implemented in order to protect the batteries from short circuit, deep discharge and overheating.

The EPS has three Solar Panel Channels equipped with hardware-based Maximum Power Point Tracking (MPPT) algorithm. Each solar panel channel has the following types of protections: overcurrent, overvoltage, ESD, overtemperature and solar panel reverse insertion. The operating temperature range is from -40°C to +150°C and the overtemperature threshold is set to +155°C (the module will turn off if this threshold is reached and restart automatically when the temperature decreases to +130°C).

Due to safety reason and according to CubeSat design specification two deployment connectors and one Remove-Before-Flight connector are located on the EPS to connect/disconnect the internal battery pack(s) from the EPS module.

The module has two Latch-Up Protected (LUP) outputs. The trip current threshold is 2A for both LUP outputs. If the trip current threshold is reached the LUP output is disconnected. An auto retry mechanism is implemented and every 15ms the LUP outputs check if the current is below the trip threshold for normal operation to continue. This trip condition can be reported to an external module.

There are two USB port located on the EPS – USB mini B and PUSB. The USB mini B port can be used for monitoring and control of the EPS module. When the jumper JMP2 is inserted the internal batteries can be charged through this connector. The secondary USB connector (PUSB) is connected electrically in parallel to the USB mini B one. The purpose of this connector is to allow the user to access the EPS module when the satellite is fully assembled.

The EPS module has six general purpose outputs. Every output can be switched between 2.7V and ground. All outputs are protected with diodes and 10k pull-down resistors, which enables other modules to control them at the same time.

The aluminum housing of the EPS modules improves the thermal capabilities of the whole system, reduces the EMC, and protects the electronics from radiation particles.

#### 4.1 EPS Module Monitoring

There is built-in firmware in the EPS module for monitoring, which can report (via the external interfaces) the following parameters:

- Voltage and current generated by each solar panel
- Combined voltage and current of all three Solar Panel Channels
- Output current of each power bus (5V BUS, 3.3V BUS, Battery BUS and BCR BUS)
- Battery pack(s) voltage, current and temperature (one temperature sensor per battery cell)
- Up to three external temperature sensors (can be mounted anywhere in the satellite)
- Critical flag status: power cycle, low voltage, EPS fault conditions, over temperature, and minimum and maximum temperatures reached for each battery cell.
- On/Off status of the output power buses
- On/Off status of all six general-purpose outputs of the EPS module
- Charge mode status
- Self-lock function status
- Battery heater status

#### 4.2 EPS Module Control

The firmware provides control (via the external interfaces) of the following features:

- On/Off state of the self-lock function (or via JMP1)
- On/Off state of the power BUS: BCR, 3.3V, 5V and 'battery raw'
- On/Off state of the 3.3V and 5V LUP outputs
- On/Off state of the six general-purpose outputs
- Set the battery charge mode (4 different options/currents)
- On/Off state of the battery heaters

## 5 BLOCK DIAGRAM

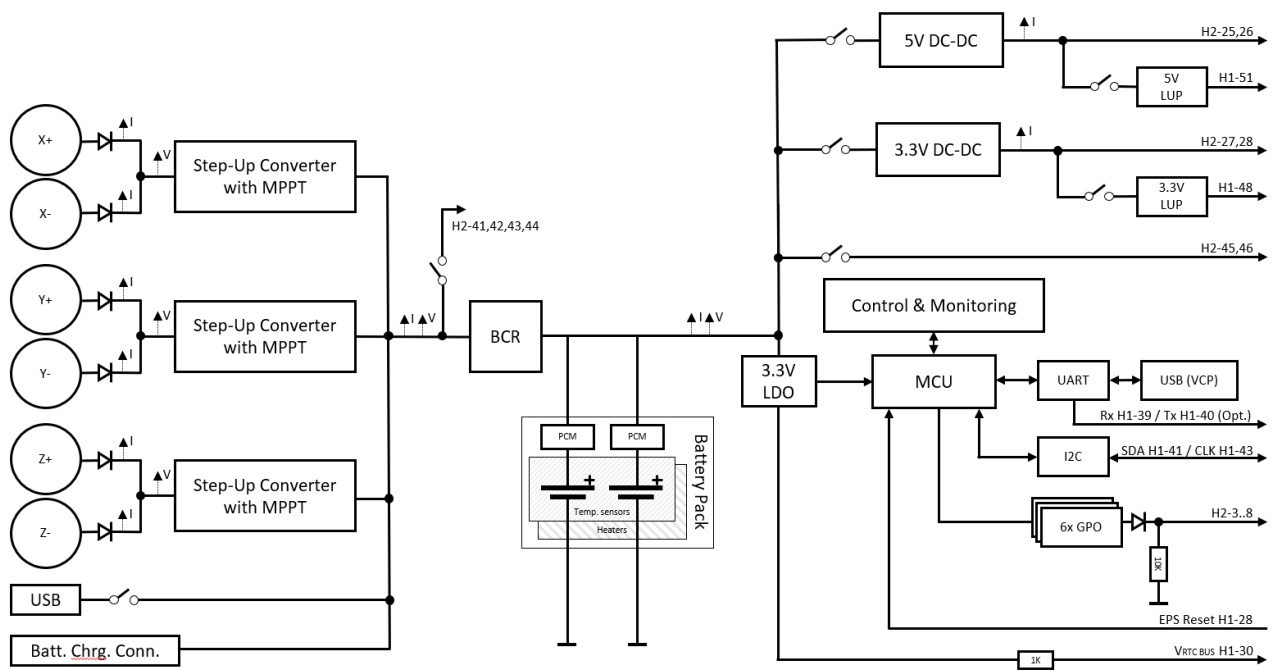

Figure 2: Block diagram of the EPS Module

## 6 CONNECTOR PINOUT

### 6.1 Location of Connectors

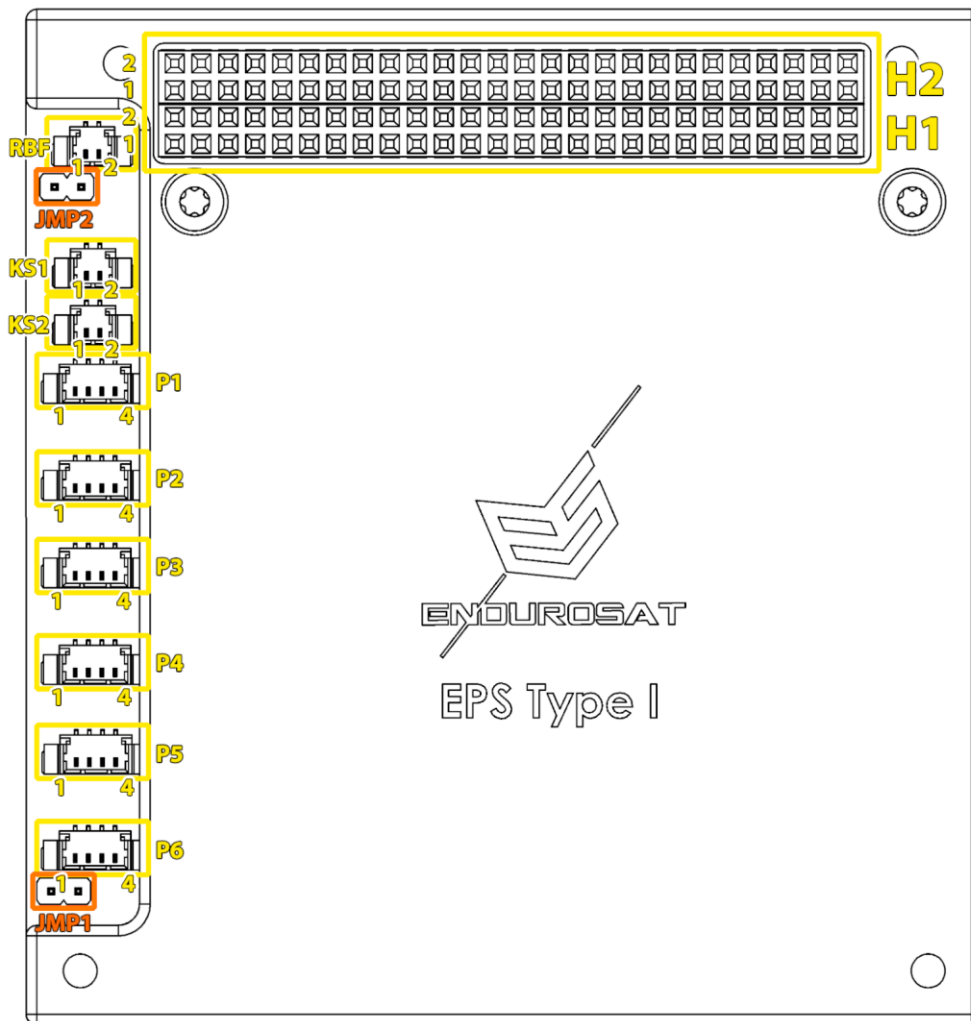

Figure 3: Location and Pinouts of Top Side Connectors

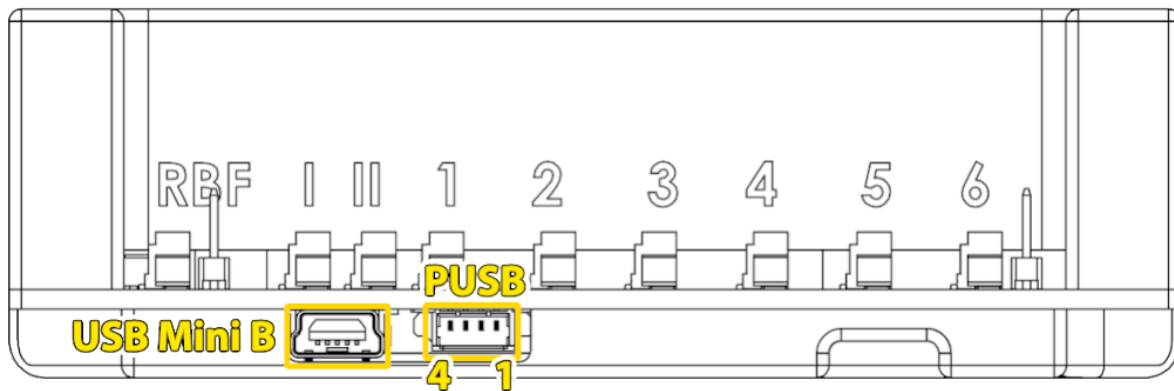

Figure 4: Location and Pinouts of Bottom Side Connectors



6.2 H1 & H2 - PC/104 Stack Connector

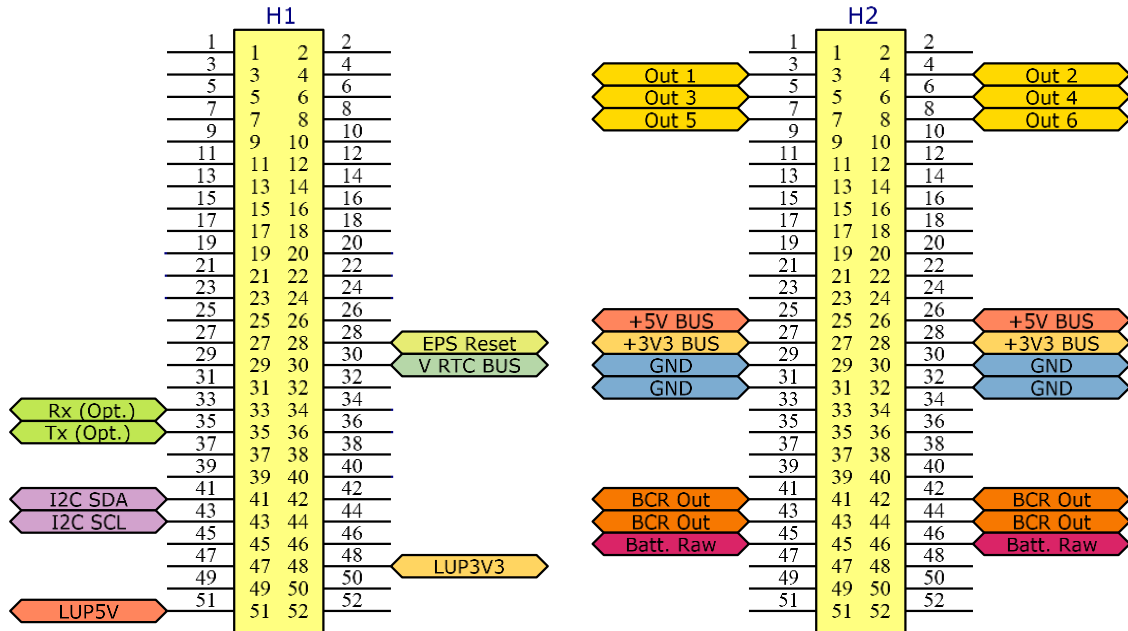

Figure 5: Pinouts of PC/104 Stack Connector

6.3 H1 – Stack Connector

Pin	Mnemonic
H1-28	EPS Reset
H1-30	V <sub>RTC</sub> BUS
H1-39	UART RX <sup>1</sup>
H1-40	UART TX <sup>1</sup>
H1-41	I2C SDA
H1-43	I2C CLK
H1-48	LUP1 3.3V
H1-51	LUP2 5V

<sup>1</sup> Optional – Hardware Customizable

Table 1: Pinouts: H1 of PC/104 Stack Connector

6.4 H2 – Stack Connector

Pin	Mnemonic
H2-3	OUT1
H2-4	OUT2
H2-5	OUT3
H2-6	OUT4
H2-7	OUT5
H2-8	OUT6
H2-25	5V BUS
H2-26	5V BUS
H2-27	3.3V BUS
H2-28	3.3V BUS
H2-29	GND
H2-30	GND
H2-31	GND
H2-32	GND
H2-41	BCR Out
H2-42	BCR Out
H2-43	BCR Out
H2-44	BCR Out
H2-45	VBATT BUS
H2-46	VBATT BUS

Table 2: Pinouts: H2 of PC/104 Stack Connector

6.5 P1 to P6 - EPS Solar Panel Connectors

The EPS module has six solar panel connectors from P1 to P6, and they are 4 pin MOLEX Picoblade 53398-0471. EnduroSat's recommended configuration is as follows:

EPS Solar Panel Connector	Axis
P1	Z+
P2	Z-
P3	Y+
P4	Y-
P5	X+
P6	X-

Table 3: EPS Solar Panel Connectors and Associated Axis

This configuration can be modified, taking into account that the pairs: P1 and P2, P3 and P4, P5 and P6 should be connected to the solar panels on opposite sides of the same axis.

The pinouts for an EPS Solar Panel Connector are the same for each of the 6 connectors (P1 - P6):

Pin	Mnemonic	Description
1	-	Negative
2	-	Negative
3	+	Positive
4	+	Positive

Table 4: Pinouts of each EPS Solar Panel Connector

### 6.6 USB Connectors

Pin	Mnemonic	Description
1	+5V	+5Vdc USB Input
2	USBN	Data Negative
3	USBP	Data Positive
4	GND	Ground

Table 5: Pinouts of PUSB Connector

## 7 ELECTRICAL CHARACTERISTICS

Parameter	Unit	Condition	Min	Typ	Max
<b>Battery Capacity</b>					
Capacity	mAh	EPS with 1 battery pack	2640	2800	
	mAh	EPS with 2 battery packs	5280	5600	
	Wh	EPS with 1 battery pack		10.4	
	Wh	EPS with 2 battery packs		20.8	
<b>Battery Charger</b>					
EOC voltage	V		4.08	4.1	4.12
Charge current	mA	Charge Mode 4	755	815	875
	mA	Charge Mode 3	540	580	620
	mA	Charge Mode 2 (by default)	430	460	490
	mA	Charge Mode 1	215	230	245
<b>Battery Discharge</b>					

## DATASHEET - EPS I & EPS I PLUS

Over Discharge Detection	V	Limited by PCM	2.24	2.3	2.36
Over Current Detection	mA	EPS with 1 battery pack (limited by PCM)		4000	9000 (8 to 16ms)
	mA	EPS with 2 battery packs (limited by PCM)		8000	16000 (8 to 16ms)
Exp. Cycle Life	mAh	Discharge @ 0.5/1C, 23 ±2°C;	500 Cycles ≥ 2196 mAh		
<b>Unregulated Battery Bus</b>					
Output voltage	V	Firmware defined	3.5		4.12
Output current	mA	EPS with 1 battery pack (limited by PCM)		4000	9000 (8 to 16ms)
	mA	EPS with 2 battery packs (limited by PCM)		8000	16000 (8 to 16ms)
<b>+5 V Bus</b>					
Output voltage	V		4.88	5	5.15
Output current	mA	EPS with 1 battery pack			2000
	mA	EPS with 2 battery pack			4000
Operating frequency	kHz		50 0	535	560
Efficiency		$V_{batt} = 4; I_{5VBUS} = 2A$	82%	84%	86%
<b>+3.3 V Bus</b>					
Output voltage	V		3.3	3.38	3.45
Output current	mA	EPS with 1 battery pack			3000
	mA	EPS with 2 battery pack			4000
Operating frequency	kHz		465	495	525
Efficiency		$V_{batt} = 4V; I_{3.3VBUS} = 2A$	72%	76%	78%
<b>Module Consumption</b>					
Power Consumption	mW	Normal Operation. LUP5V & LUP3V3 are OFF		75	
	mW	Low Voltage or High Temperature State. All Buses are OFF		43	
Current Consumption	mA	Batt. Low State @3.3V		13	
	mA	Normal Operation @3.7V		20	
	mA	LUP3V3 & LUP5V	3.9		5
	mA	Heater 1		150	
	mA	Heater 2		200	
	mA	Heater 3		230	
Fault Current Threshold (auto retry every 15ms)	A	LUP3V3 & LUP5V	1.75		2.2

Solar Panels Input					
Voltage	V	@25°C	0	4.66	5.5
Current	mA	@25°C		517	1800
Power	W	@25°C		2.6	
Integrated blocking diode forward voltage (V <sub>F BLOKING DIODE</sub> )	V	@1A & 25°C		0.325	
		@0.5A & 25°C		0.275	

Table 6: Electrical Characteristics of EPS I & EPS I Plus Modules

## 8 MECHANICAL DRAWING

The following pictures show the external dimensions of a fully assembled EPS module. The EPS module, as already mentioned, has two configurations: EPS I with one battery pack, and EPS I Plus with two battery packs. The bottom side of the module has two openings, which can be used for routing cables within the satellite. The top view is the same for both configurations (see Figure ).

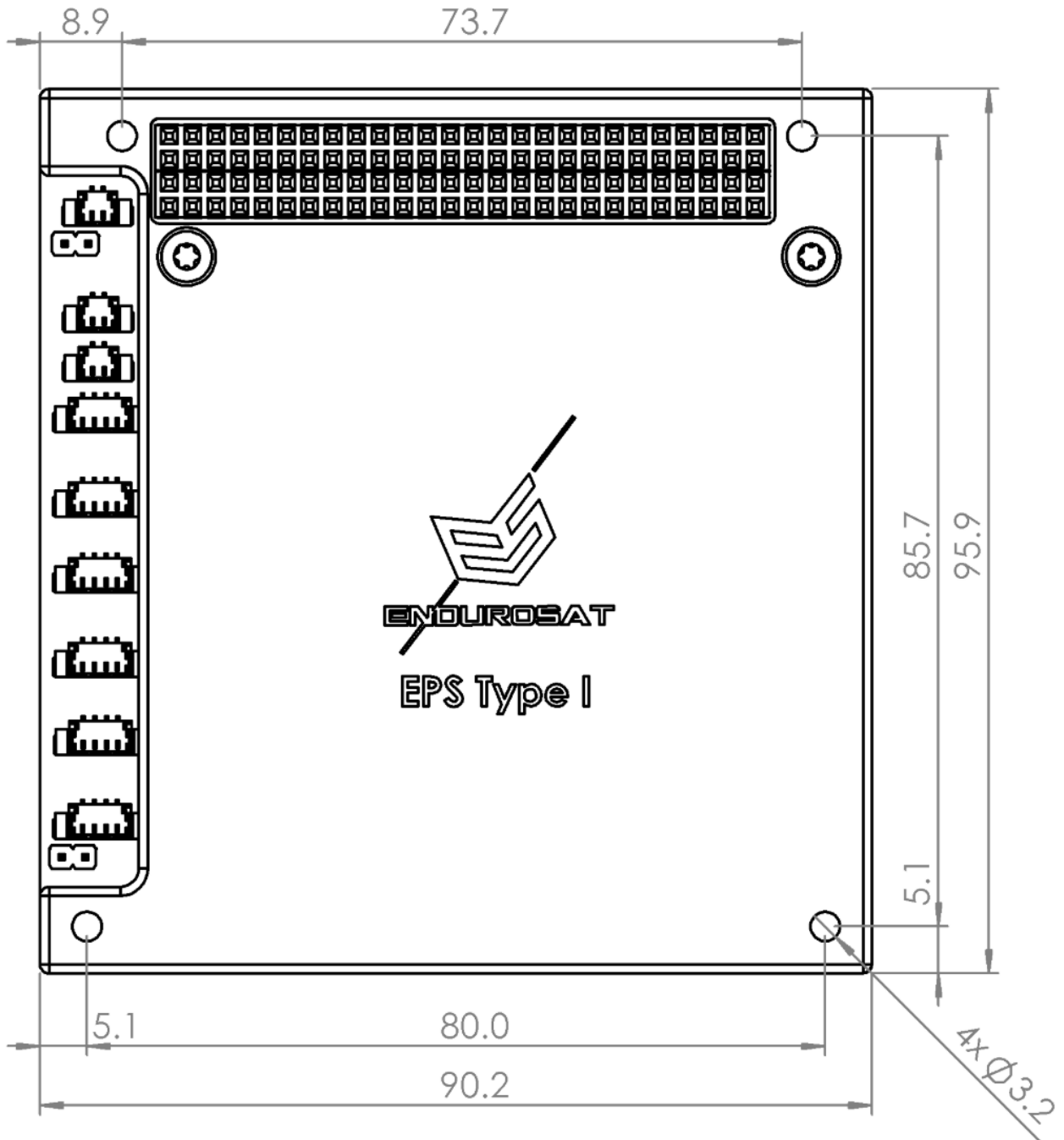

Figure 6: EPS Module - Top View (all dimensions are in mm)

The bottom part of both the EPS I and the EPS I Plus module are the same. There are two openings to assist in routing cables within the satellite (see Figure , Figure and Figure 0).

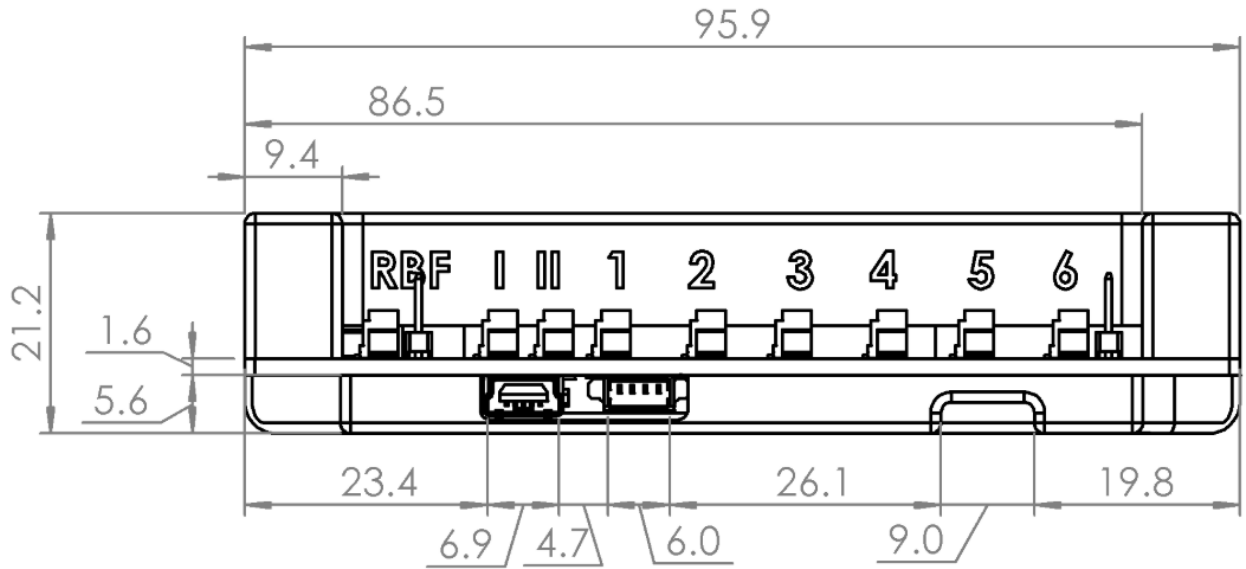

Figure 7: EPS I Module with one Battery Pack – Side View

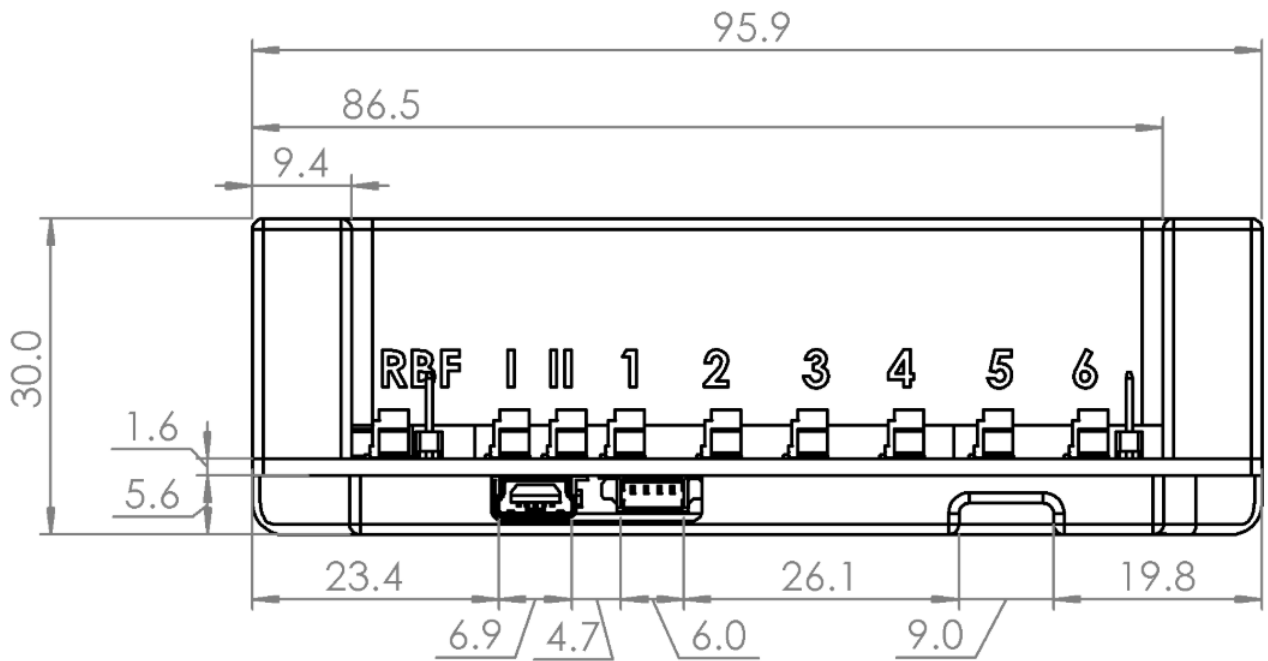

Figure 8: EPS I Plus Module with two Battery Packs – Side View

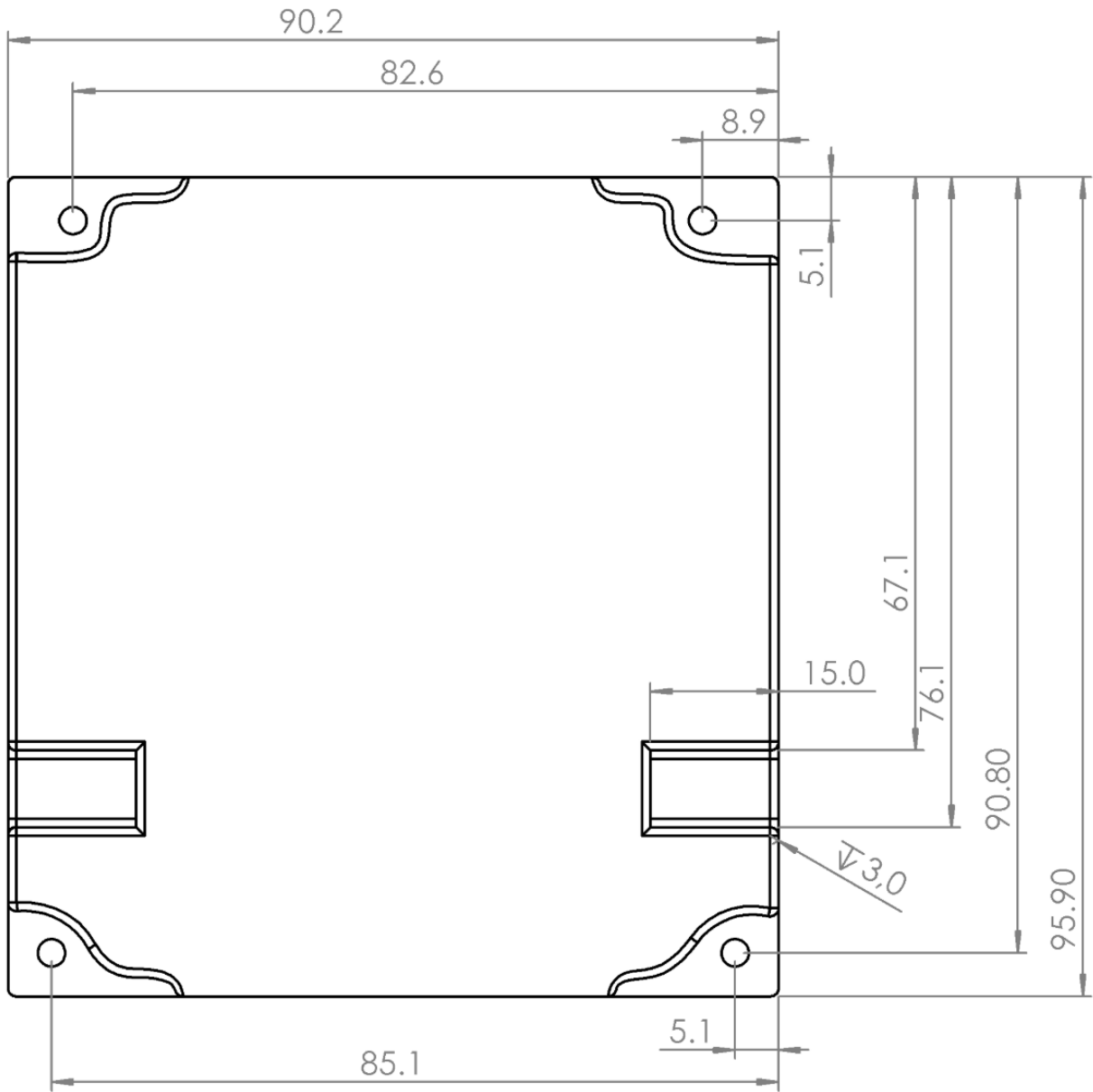

Figure 9: EPS Module - Bottom View with Openings



## 9 ENVIRONMENTAL AND MECHANICAL TEST

A full campaign of qualification tests was performed on the qualification engineering model. The qualification test levels, and duration follow the ESA standard ECSS-E-ST-10-03C and GEVS: GSFC-STD-7000A. The tests performed were:

- Thermal Cycling
- Thermal Vacuum
- Random Vibration
- Sine Vibration
- Shock Test
- Total Ionizing Dose

A test report can be provided upon request.

## 10 HANDLING AND STORAGE

Particular attention shall be paid to the avoidance of damage to the EPS during handling, storage and preservation. The handling of the EPS module should be performed in compliance with the following instructions:

- Handle using PVC, latex, cotton (lint free) or nylon gloves.
- The environment where the EPS module will be handled shall meet the requirements of a Class 100,000 environment. It shall be free of contaminants such dust, oil, grease, fumes and smoke from any source.
- Store in such a manner as to exclude stress and prevent damage.
- To prevent the deterioration of the power module, it must be stored in a controlled environment, i.e. the temperature and humidity levels shall be maintained in the proper ranges:
  - Ideal storage temperature range: 15°C to 27°C
  - Ideal storage humidity range: 30% to 60% relative humidity (RH)

## 11 WARNINGS



This product uses semiconductors that can be damaged by electrostatic discharge (ESD). Observe precautions for handling



Sensitive electronic device. Do not ship or store near strong electrostatic, magnetic, electromagnetic, or radioactive fields.



### LITHIUM ION RECHARGEABLE BATTERY

Caution! May explode if disposed of in fire

- Do not incinerate or place near an open flame
- Do not drop, crush, puncture or disassemble battery
- Do not short terminals
- Do not expose to temperatures above 140°F/60°C
- Do not replace by a battery other than that specified by the manufacturer

